



Custom Fabrications



Armstrong can design and fabricate custom packages to fit your application needs.

ASME Packages



Armstrong can design and fabricate all ASME packages to meet your plant piping requirements.

Standard



Armstrong's standard simplex (shown), duplex, triplex or quadraplex packages are unparalleled in quality and craftsmanship.



General Applications

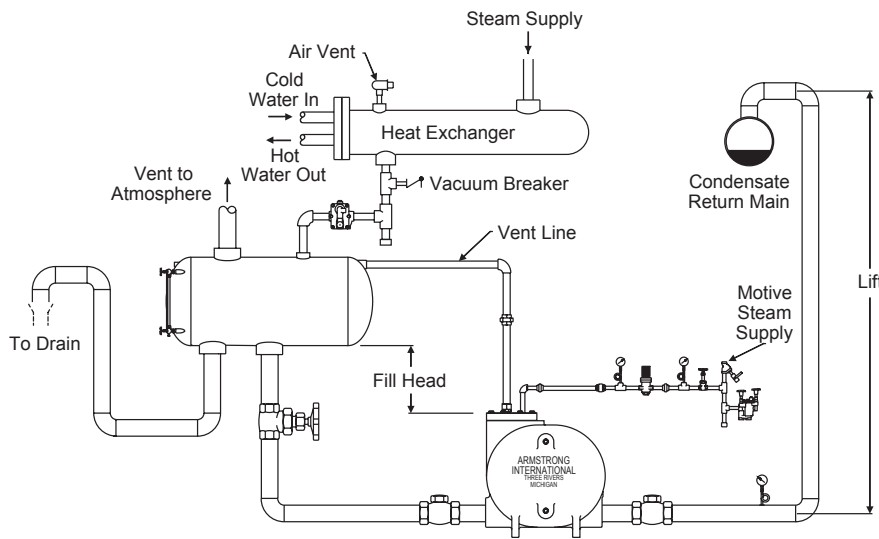

Multiple or single traps discharging to vented receiver.

OPEN SYSTEMS

For the majority of applications, a steam trap is recommended on each piece of heat exchange equipment. The steam trap, or traps, discharge to a vented receiver where flash steam will be vented to the atmosphere. The pump trap is located downstream and below the vented receiver, allowing for proper fill head height. See tables on page 221 and 224 for vented receiver and vent sizing for an open system.

Note 1: Drip trap may be discharged into the receiver, the return line or to the drain.

CLOSED SYSTEMS

Applications exist where it is desirable to tie the vent line back into the heat exchange space, equalizing the pressure in the heat exchanger, reservoir/piping and the pump trap. This allows water to flow by gravity down to the pump where it can be returned. Valuable Btu's remain within the system due to no flash steam loss to the atmosphere through the vent. Closed system applications can also be used to drain liquid from the equipment under a vacuum. See installation and operation manual IB-100. See tables on pages 221 and 224 for reservoir pipe sizing.

Note 1: If steam motive is used, the drip trap may be discharged into the return line or to the drain.

Note 2: Vent piping from the pump trap can be connected to the inlet side of the equipment being drained if the pressure drop across the equipment is less than .5 psi (0.03 bar) and there is a minimum of 24" (609 mm) of fill head present.

Note 3: A vacuum breaker must be installed if the vent piping from the pump trap is connected to the receiver. If the equipment modulated down to a sub-atmospheric condition, the vacuum breaker will open to equalize the system and provide adequate drainage.

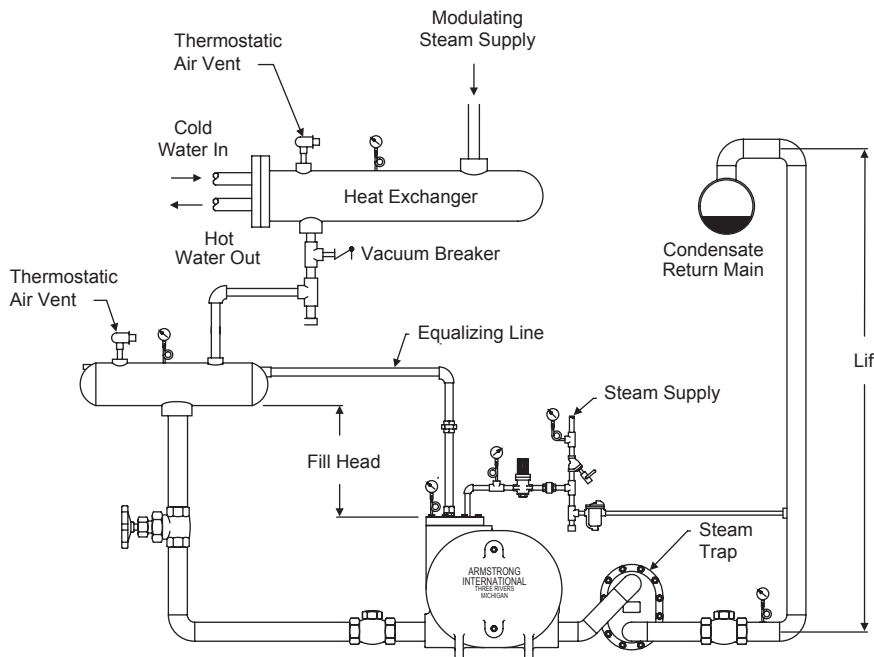

Draining steam coil or heat exchanger when steam pressure may exceed the return line pressure, a steam trap is required on the discharge side of the pump trap. Request installation and operation manual IB-100.



Double Duty[®] Typical Application

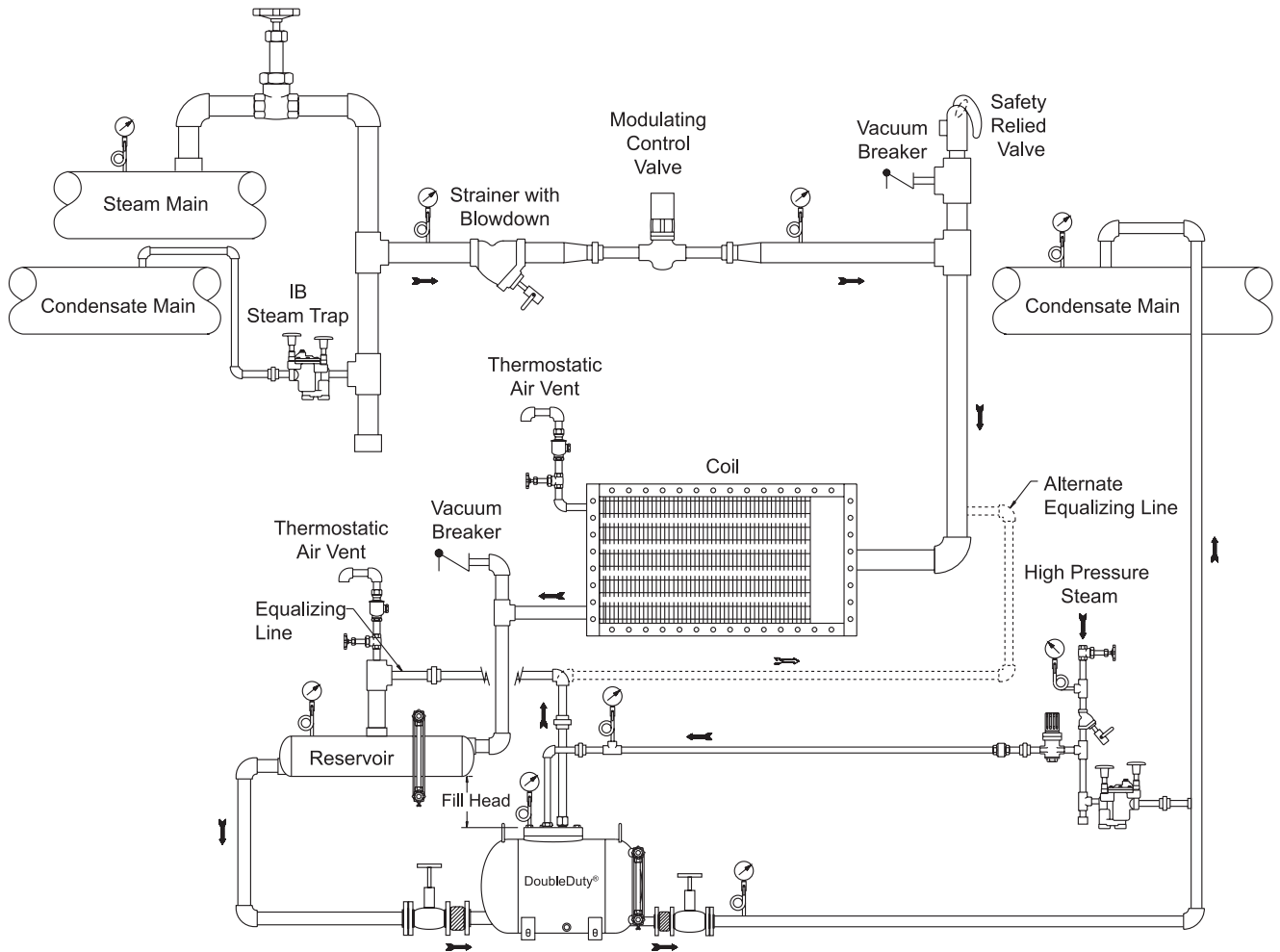

Common Applications for Condensate Armstrong Pump Traps

- Air Heating Coils
- Plate and Frame Heaters
- Jacketed Kettles
- Vacuum Space
- Flash Tanks
- Shell and Tube Heat Exchangers
- Absorption Chillers
- Low Pressure Applications

Any application using modulated control.





Condensate Drainage From Modulated Steam/Temperature Controlled Equipment

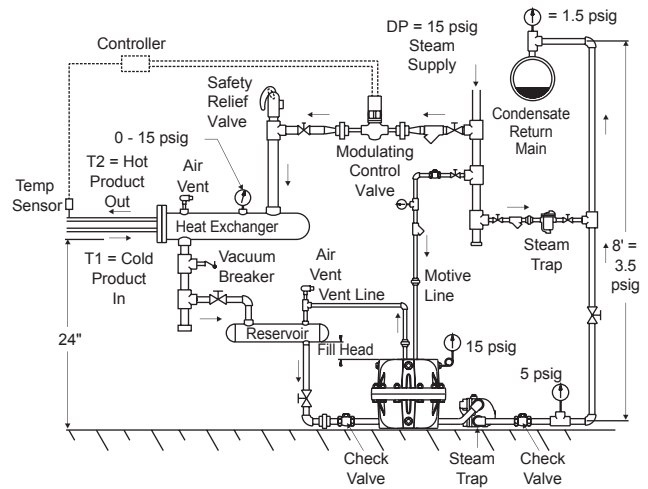
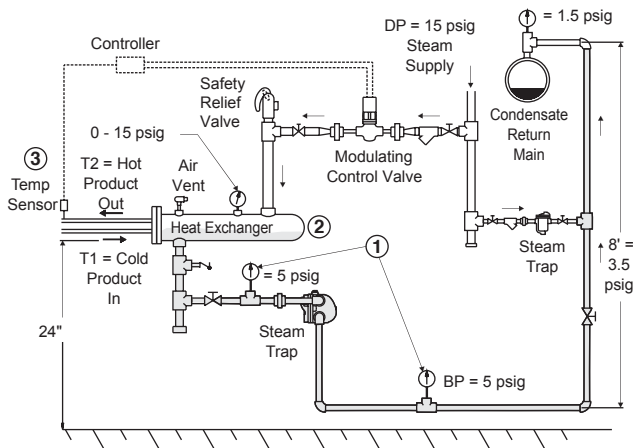

Problem: "Stall" Condition on Modulated Steam Control

Modulated steam controls are required to change steam pressure in the heat exchanger to control accurate product output temperature. Due to these varying steam pressure changes, a stall condition exists in all heat exchangers where condensate cannot flow through the steam trap due to insufficient pressure differential. Under the stall condition, partial or complete flooding will occur. Reference figure above noting the stall conditions and problems that can occur.

Armstrong Solution

The Armstrong pump trap and steam trap combination is the total solution to the stall condition by removing condensate under all system conditions. When the steam system pressure is sufficient to overcome the back pressure, the steam trap operates normally. When the system pressure falls to the stall condition, the pump trap operates and pumps condensate through the steam trap. Temperature control and condensate drainage are assured under all system conditions.

NOTE: The pump trap is sized for the stall conditions.

NOTE: Closed-loop solution shown. See page 234 for vented system arrangement.

Problems

1. Stall condition—no condensate drainage due to insufficient pressure to move condensate through the steam trap
2. Heat exchange equipment floods causing equipment damage from:
 - Water hammer due to steam and condensate occupying the same space
 - Corrosion due to carbonic acid forming from sub-cooled condensate reabsorbing trapped carbon dioxide and noncondensable gases
3. Inaccurate temperature control

Stall Chart

Use of the stall chart on right will determine the point where flooding will occur.

Application information required:

DP = design pressure to heat exchanger
 BP = back pressure
 T1 = incoming temperature
 T2 = exit temperature
 MT = mean temperature

Example

15 psig
 5 psig
 60°F
 140°F
 100°F

Stall Information:

SL = stall load %
 ST = stall load temperature

85%
 72°F

