

FORGED STEEL GLOBE VALVE

Class 1500 , 1/2"-2"



CONSTRUCTION IS AS FOLLOWS:

- Full Port or Conventional Port
- Outside Screw and Yokes (OS & Y)
- Two piece self aligning packing gland
- Seal welded bonnet
- Integral backseat
- Socket weld Ends to ANSI/ASME B16.11
- Screwed Ends (NPT) to ANSI/ASME B1.20.1

DESIGN CONSTRUCTION & SPECIFICATIONS

Forged steel globe valves conform to API 602, BS 5352, and ANSI B16.34. Each are tested according to API 598. and marking is per MSS SP-25.

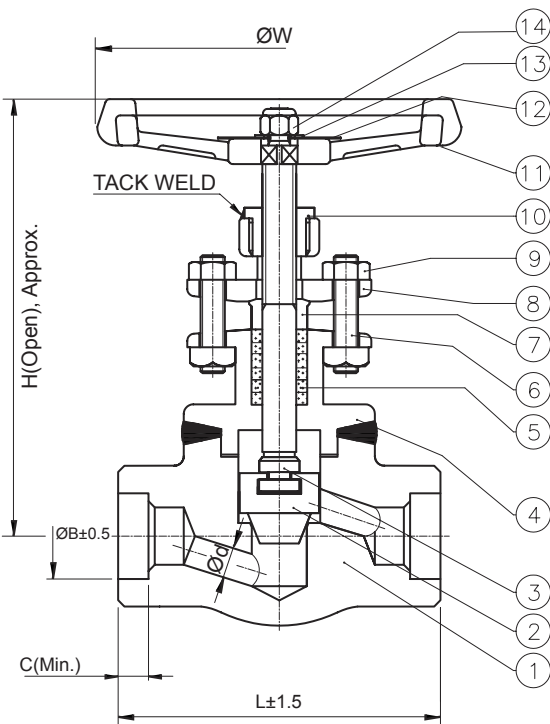

Standard Material Specifications		
No.	Part Name	Materials
1	Body	A182-F22
2	Disc	A182-F6a HF No.6
3	Stem	A182-F6a
4	Bonnet	A182-F22
5	Gland Packing	Flexible Graphite
6	Gland Bolt	A193-B16
7	Gland	A276-410
8	Gland Flange	A182-F22
9	Gland Nut	A194-4
10	Yoke Bush	A276-410
11	Handwheel	A197
12	Nameplate	SS 304
13	H/W Washer	Stainless Steel
14	H/W Nut	A194-4

Dimensions (mm)

NPS (inch)	H	L	ØW	Ød	ØB	C
1/2"	170	92	100	10	21.8	10
3/4"	205	111	120	13	27.2	13
1"	233	140	150	17.5	33.9	13
1-1/4"	256	152	150	22.5	42.7	13
1-1/2"	292	172	180	28.6	48.8	13
2"	335	220	220	35	61.2	16

