

Two-piece ball valve, floating ball. metal seated. single side

1/2" - 4", Class 150/300

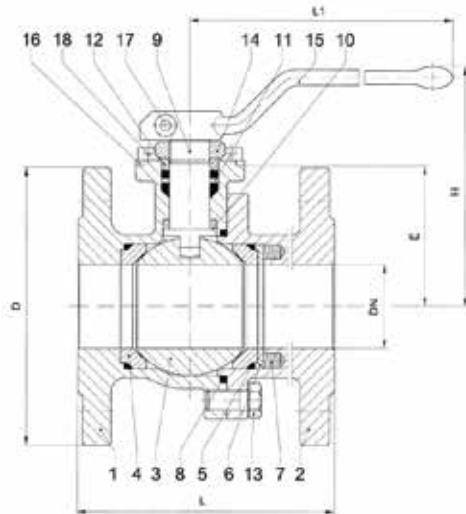

**Flanged ball valve
full bore
face to face acc. to ANSI B 16.10
flanges acc. to ANSI B 16.5**

Specification:

Two-piece ball valve, flanges acc. to ANSI B 16.5, face to face dimensions acc. to ANSI B 16.10, full bore, blow-out-proof stem, body material stainless steel (ASTM A351-CF8M) or carbon steel (ASTM A216-WCB), antistatic device, free of non ferrous metals, seat 1.4571 (AISI 316 Ti)/1.4404 (AISI 316 L) hard facing metal coated, single side spring loaded seat ring, stem packing cone ring construction acc. to temperature use, dynamic loaded adjustable, top flange DIN EN ISO 5211, approved by PED, certified acc. to GERMAN clean air act VDI 2440, Fire-Safe acc. to DIN EN ISO 10497, with lever.

Marking: INTEC K221

No.	Part	Material	Material
High temperature design			
1	body	ASTM A216-WCB	ASTM A351-CF8M
2	cap	ASTM A216-WCB	ASTM A351-CF8M
3	ball	1.4408 (ASTM A351-CF8M) hard facing metal coated	
4	seat	1.4571 (AISI 316 Ti)/1.4404 (AISI 316 L) hard facing metal coated	
5	bearing ring seal	Graphite	
6	follower ring	1.4571 (AISI 316 Ti)/1.4404 (AISI 316 L)	
7	spiral spring	Inconel X750	
8	body seal	Graphite	
9	stem	< 250°C	350°C
		1.4462 (A479 UNS S31803)	1.4313 (A479 UNS S41500)
			400°C
10	below seal	E-carbon	
11	upper seal	1.4571 (AISI 316 Ti)/1.4404 (AISI 316 L)/Graphite	
12	bearing	E-carbon	
13	hex. screw	A4-70 (A193-B8M)	
14	hex. nut self-locking	A2/1.4301 (AISI 304)	
15	lever	1.4408 (ASTM A351-CF8M)/1.4308 (ASTM A351-CF8)	
16	stopper	1.4301 (AISI 304)	
17+18	allen screw	A2-70 (A193-B8)	
Fire-Safe design			
8	combined body seal	KF-Graphite	
10	below seal	KFGN/Graphite	
11	upper seal	KFAM/Graphite	
12	Fire-Safe seal	Graphite	
	ring	1.4571 (AISI 316 Ti)/1.4404 (AISI 316 L)	
	thrust washer	PEEK	
Standard design			
5	bearing ring seal	KF	
8	body seal	KF	
10	below seal	KFGN/Graphite	
11	upper seal	KFAM/Graphite	
12	bearing	PEEK	

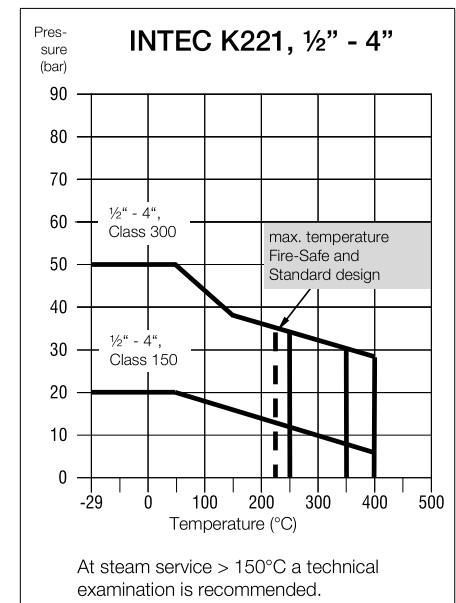

**Ordering example:
INTEC K221, 2", Class 300,
CF8M, high temperature**

Dimensions

NPS inch	dimensions		L 150 lbs.	L 300 lbs.	D 150 lbs.	D 300 lbs.	E	top flange ISO	torque		ca. weight	
	H	L1							Nm* 150 lbs.	Nm* 300 lbs.	kg 150 lbs.	kg 300 lbs.
1/2"	95	160	108	140	89	95	39.5	F05	30	37	2.1	2.9
3/4"	105	160	117	152	98	117	46	F05	37	50	3.0	4.2
1"	114	180	127	165	108	124	49.5	F05	42	58	4.1	5.0
1 1/4"	130	180	140	178	117	133	59	F05	69	108	5.0	7.0
1 1/2"	135	300	165	190	127	156	76	F07	107	177	8.0	10.5
2"	143	300	178	216	152	165	83.5	F07	162	**	11.8	13.0
2 1/2"	155	300	190	241	178	190	94	F07	**	**	17.0	20.0
3"	197	500	203	283	190	210	102.5	F10	402	**	24.4	31.0
4"	215	500	229	305	229	254	120.5	F10	**	**	35.0	47.0

* Necessary torque measured with treated water at Δ P acc. to pressure class and room temperature.

** on request.

*last updated 08/23