



GROOVED GASKETS

Metal/soft-material gaskets



Types of gaskets

Grooved gaskets have proven extremely useful in all areas of industry, including the most demanding sealing tasks. Our grooved gaskets can be found in conventional power plants as well as in the primary circuit of nuclear power plants. In nuclear power plants, they are used e.g. as a heat exchanger gasket, as a valve cap gasket or as a manhole cover gasket on steam generators or pressurisers.

Grooved gaskets have also been used to great success in the chemical and petrochemical industries. Particularly in places where there are high pressures and temperatures, and therefore high bolt loads, to contend with. In order to avoid damage to the flanges by the metal core, grooved gaskets are generally used with layers of PTFE, graphite, aluminium or silver. This gives total protection to the flanges, as the profile geometry has been specifically adjusted to suit the thickness of the layer.

We have developed a range of profiles to suit the various properties of the layer materials.

The principal purpose of the soft layers is not however to protect the flanges, but to provide a secure seal even at low minimum surface pressures. A triaxial stress is created in the profiling of the metallic carrier which has been filled with the layer material. The load capacity is limited by the breaking point of the gasket and/or flange material. The stability of this combination is therefore significantly higher than with a pure PTFE, graphite, aluminium or silver seal.

Grooved gaskets be produced in sizes ranging from a few millimetres to a diameter of 4,500 mm on our lathes. The possibility of producing gaskets with greater diameters or one-off production from drawings, such as oval gaskets, can be examined in individual cases. For gaskets in heat exchangers with partitions, it is necessary to insert partitions with grooves of the same profile.

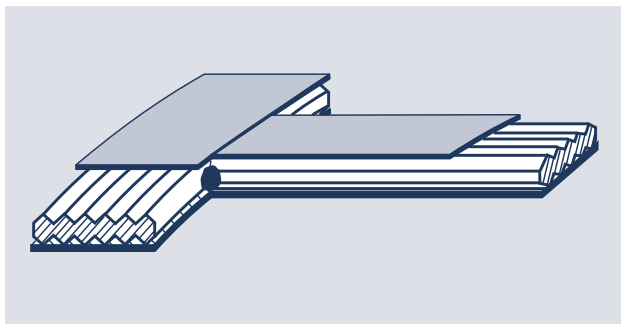

Gaskets for flanges with raised face or for smooth flanges are supplied with a centring ring, so that the gasket is centred on the bolts. If the width of the centring ring is ≤ 10 mm, then this ring is a part of the gasket (fixed central frame). At greater widths, the integrated has a stress-relieving groove (illustration 1). A loose centring ring should be used with gaseous media. The loose centring ring is also advantageous where there are large differences in temperatures between internal and external diameters. The loose centring ring is fitted in a groove (illustration 2 and 3).

The illustrations show the layout for a nominal thickness of the metal core of 4 mm.

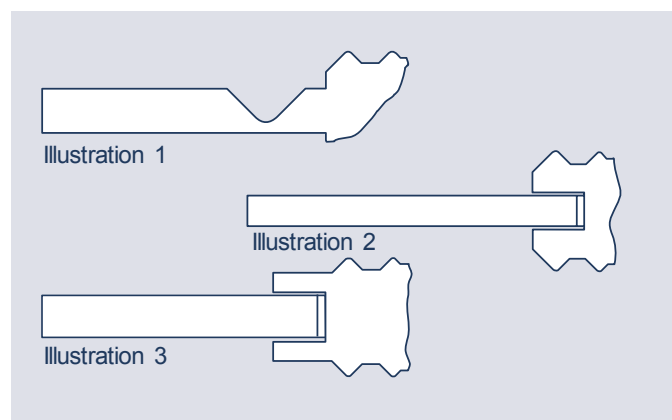

Grooved gaskets are available that conform to works standards WN 100, WN 101, WN 136, WN145 (DIN EN 1514-6), WN 146 and WN 147. Works standards 100 and 101 only contain a sealing width for all nominal pressure levels.

The sealing width $b_D = (d_2 - d_1)/2$ should always increase as the nominal pressure level increases. Due to the extremely large difference between σ_g and σ_v , in grooved gaskets, as expressed in the application security $SB = \sqrt{\sigma_g/\sigma_v}$, works standards 100 and 101 can be simplified.





GROOVED GASKETS

Metal/soft-material gaskets



Materials for the layers

PTFE, graphite and in certain cases silver or aluminium.

Soft-material layers are generally supplied glued to the gasket. When putting the gasket into use, it should be noted that the gasket is thicker around the layers.

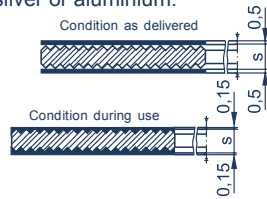

We recommend PTFE or graphite as layers for pipelines, apparatus parts or valves made from austenitic materials. The layers should be either attached without glue or a low-chloride adhesive should be used.

In metal casings in narrow gaskets where $b_D < 0,5\sqrt{d_1}$, single-part casings are used and in wide gaskets with $b_D > 0,5\sqrt{d_1}$ [mm] two-part casings are used.

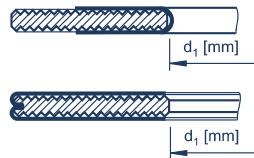

Sealing thickness and groove pitch

For flanges with tongue and groove faces and flanges with male and female faces.

In accordance with works standard 123

DN	NPS	s
to 80	resp. to 3	1,5
from 100 to 300	resp. 4 to 12	2,0
from 350 to 900	resp. 14 to 36	2,5
over 900	36	3,0
Groove pitch t:		
with B7A, B9A, B15A		= 1,0 mm
with B27A, B29A, B25A		= 1,5 mm

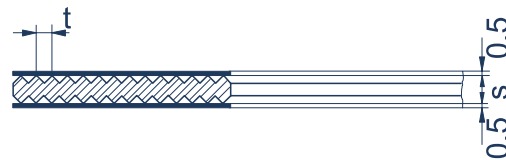

Grooved gaskets with standard profiling

In the standard profile, the peaks of the groove are on one level and the troughs are parallel to them. This profiling is designed in accordance with DIN EN 1514-6. The layer thickness for graphite, aluminium and silver should be 0.5 mm and for PTFE 0.35 mm.

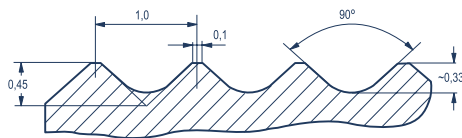

This profiling should be used with gaskets for flange connections with male or female faces or tongue and groove flanges. The minimum requirements are set out in our works standard WN 123.

Profiles

The B7A profile is for use with flange connections with tongue and groove and male and female faces. The Profile B9A with integrated centring ring should be selected for use with smooth flanges and flanges with raised face. With gaseous media, or where there are large differences in temperature between internal and external diameters, the Profile B15A with loose sheet metal centring ring should be used. The grooved insert ring conforming to E7A is for groove-on-groove flange connections.

Gasket profiles

Profile	Cross-section
B7A	
B9A	
B15A	
E7A	

Gasket limiting values

Profiles	B7A, B9A, B15A, E7A						
	Materials	1.7335 graphite	1.7335 PTFE*	1.4541 graphite	1.4541 PTFE*	1.4541 aluminium	1.4541 silver
Recommended max. roughness of the flange surfaces	μm	from 12,5	50	12,5	50	12,5	12,5
Surface pressure limits for 20 °C	N/mm^2	σ_v 15	15	σ_v 450	450	80	125
Surface pressure limits for 300 °C	N/mm^2	σ_v 30	30 ¹⁾	σ_v 390	390 ¹⁾	95	140
						420	420

1) Groove gaskets with PTFE layers are only suitable for use at 280 °C to a limited extent.

* Gaskets that are electrically isolated from the usual pipelines by two PTFE layers can become electrostatically charged. Appropriate measures must be taken to discharge any electrical charge that may arise depending on the medium.

Characteristic values according to EN 13555 can be found on our website under www.klinger-kempchen.de.



The “convex” grooved gasket

The convex grooved gaskets in Profile B27A, B29A and B25A exhibit improved sealing properties compared to standard grooved profiles.

The improvement is achieved by the decreasing depth of the groove troughs towards the midpoint of the profile. The profiling is created as a step profile.

The sealing layer made from soft, plastic deformable material creates a thicker padding at the profile centre line than in the internal and external zones. The layer thickness for graphite, aluminium and silver should be 0.5 mm and for PTFE 0.35 mm.

The specific surface pressure is greatest at the profile centre line, causing the sealing layers to flow well into the unavoidable irregularities and roughness on the flange surface. Grooved gaskets in Profile B27A, B29A and B25A reduce edge pressure.

The increased surface pressure at the profile centre line has a positive effect on the sealing properties in tilted flanges. With ordinary gaskets, when a flange is strongly tilted ($\alpha \sim 1^\circ$) it causes a raising of the internal diameter of the gasket to be observed, as the flange is now loading the seal more on the outer diameter. But with Profile B27A, B29A and B25A the contact diameter is kept at d_c . These gaskets are therefore particularly suitable for flange connections where the pressures and temperatures are constantly fluctuating.

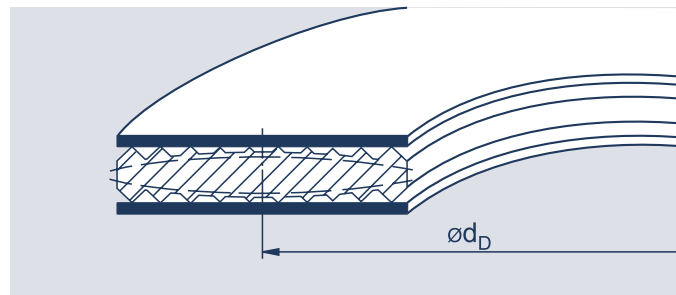

With gaseous media or large differences in temperature between the internal and external diameters, Profile B25A with loose sheet metal central edge should be used.

Gasket profiles

Profile	Cross/section
B27A	
B29A	
B25A	
E27A	

Profiles

The B27A profile is for use with flange connections with tongue and groove and male and female faces. The Profile B29A with integrated centring ring should be selected for use with smooth flanges and flanges with raised face. The grooved insert conforming to E27A is for groove-on-groove flange connections.

Surface pressures

The minimum surface pressure σ_v is determined by the layer material used with the convex grooved gasket. The highest permissible surface pressure at a temperature of ϑ is σ_ϑ and this determines the “allowable gasket load reaction”. The maximum allowable surface pressure σ_ϑ is determined by the material used in the metal core.

Gasket limiting values

Profiles	B27A, B29A, B25A, E27A										
	Materials		1.0038 graphite	1.5415 graphite	1.5415 PTFE*	1.4541 graphite	1.4541 PTFE*	1.4828 graphite	1.4541 aluminium	1.4541 silver	1.4828 silver
Recommended max. roughness (R_z) of the flange surfaces	μm	from to	12,5 50	12,5 50	50 100	12,5 50	50 100	12,5 50	12,5 25	12,5 25	12,5 25
Surface pressure limits for 20 °C	N/mm ²	σ_v	15	15	15	15	15	15	70	100	100
		σ_ϑ	350	450	450	500	500	500	500	500	500
Surface pressure limits for 300 °C	N/mm ²	σ_v	20	20	20 ¹⁾	20	20 ¹⁾	20	80	110	110
		σ_ϑ	210	330	330 ¹⁾	420	420 ¹⁾	420	420	420	500

1) Groove gaskets with PTFE layers are only suitable for use at 280°C to a limited extent.

* Gaskets that are electrically isolated from the usual pipelines by two PTFE layers can become electro-statically charged. Appropriate measures must be taken to discharge any electrical charge that may arise depending on the medium.



GROOVED GASKETS

Metal/soft-material gaskets

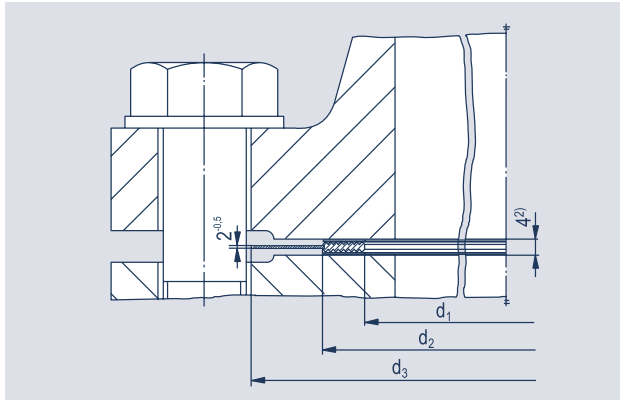

Works standard 145 = DIN EN 1514-6 for DIN flanges

Ordering example for a grooved gasket with layers,
Profile B29A, DN 100, PN 40, works standard 145,
made of ...1):

**Grooved gasket B29A, DN 100, PN 40, works standard 145,
1.4541 / PTFE**

For DIN flanges

DN	d ₁	d ₂ PN 10- PN 40	d ₂ PN 63- PN 160	d ₂ PN 250- PN 400	d ₃									
					PN 10	PN 16	PN 25	PN 40	PN 63	PN 100	PN 160	PN 250	PN 320	PN 400
10	22	36	36	36	46	46	46	46	56	56	56	67	67	67
15	26	42	42	42	51	51	51	51	61	61	61	72	72	78*
20	31	47	47	47	61	61	61	61	72	72	-	-	-	-
25	36	52	52	52	71	71	71	71	82	82	82	83	92	104
32	46	62	62	66	82	82	82	82	-	-	-	-	-	-
40	53	69	69	73	92	92	92	92	103	103	103	109	119	135
50	65	81	81	87	107	107	107	107	113	119	119	124	134	150
65	81	100	100	103	127	127	127	127	137	143	143	153	170	192
80	95	115	115	121	142	142	142	142	148	154	154	170	190	207
100	118	138	138	146	162	162	168	168	174	180	180	202	229	256
125	142	162	162	178	192	192	194	194	210	217	217	242	274	301
150	170	190	190	212	217	217	224	224	247	257	257	284	311	348
175	195	215	215	245	247	247	254	265	277	287	284	316	358	402
200	220	240	248	280	272	272	284	290	309	324	324	358	398	442
250	270	290	300	340	327	328	340	352	364	391	388	442	488	-
300	320	340	356	400	377	383	400	417	424	458	458	536	-	-
350	375	395	415	-	437	443	457	474	486	512	-	-	-	-
400	426	450	474	-	489	495	514	546	543	572	-	-	-	-
450	480	506	-	-	539	555	-	571	-	-	-	-	-	-
500	530	560	588	-	594	617	624	628	657	704	-	-	-	-
600	630	664	700	-	695	734	731	747	764	813	-	-	-	-
700	730	770	812	-	810	804	833	852	879	950	-	-	-	-
800	830	876	886	-	917	911	942	974	988	-	-	-	-	-
900	930	982	994	-	1017	1011	1042	1084	1108	-	-	-	-	-
1000	1040	1098	1110	-	1124	1128	1154	1194	1220	-	-	-	-	-
1200	1250	1320	1334	-	1341	1342	1364	1398	1452	-	-	-	-	-
1400	1440	1522	-	-	1548	1542	1578	1618	-	-	-	-	-	-
1600	1650	1742	-	-	1772	1764	1798	1830	-	-	-	-	-	-
1800	1850	1914	-	-	1972	1964	2000	-	-	-	-	-	-	-
2000	2050	2120	-	-	2182	2168	2230	-	-	-	-	-	-	-
2200	2250	2328	-	-	2384	2378	-	-	-	-	-	-	-	-
2400	2460	2512	-	-	2594	-	-	-	-	-	-	-	-	-
2600	2670	2728	-	-	2794	-	-	-	-	-	-	-	-	-
2800	2890	2952	-	-	3014	-	-	-	-	-	-	-	-	-
3000	3100	3166	-	-	3228	-	-	-	-	-	-	-	-	-

- Flanges compliant with the standard not available

Dimensions in mm

* WN 145

1) Specify material when placing order

2) Please arrange other thicknesses when ordering.





GROOVED GASKETS
Metal/soft-material gaskets

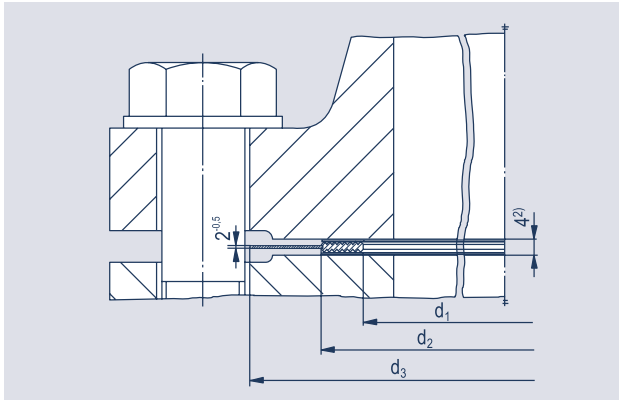

Works standard 146 for flanges

in accordance with ANSI B16.5

Ordering example for a grooved gasket with layers, Profile B9A, NPS 5, for ANSI flanges, Class 600, works standard 146, made of ...1):

Grooved gasket B9A, NPS 5, Class 600, works standard 146, 1.4541 / graphite

For flanges in accordance with ANSI B16.5

NPS	d ₁	d ₂ Class 150-300	d ₂ Class 400-600	d ₂ Class 900-2500	Class						
					150	300	400	600	900	1500	2500
1/2	20	30	30	30	44,4	50,8	50,8	50,8	60,3	60,3	66,7
3/4	25	35	35	35	53,9	63,5	63,5	63,5	66,7	66,7	73,0
1	32	42	42	42	63,5	69,8	69,8	69,8	76,2	76,2	82,5
1 1/4	40	56	56	56	73,0	79,4	79,4	79,4	85,7	85,7	101,6
1 1/2	45	61	61	61	82,5	92,1	92,1	92,1	95,2	95,2	114,3
2	60	80	80	80	101,6	108,0	108,0	108,0	139,7	139,7	142,8
2 1/2	70	90	90	90	120,6	127,0	127,0	127,0	161,9	161,9	165,1
3	85	105	105	110	133,4	146,1	146,1	146,1	165,1	171,5	193,7
3 1/2	100	120	120	-	158,8	161,9	158,7	158,7	-	-	-
4	110	130	130	135	171,5	177,8	174,6	190,5	203,2	206,4	231,7
5	135	155	155	165	193,7	212,7	209,5	238,1	244,5	250,8	276,2
6	160	180	180	195	219,1	247,7	244,5	263,5	285,8	279,4	314,3
8	210	230	230	250	276,2	304,8	301,6	317,5	355,6	349,3	384,1
10	265	285	295	315	336,5	358,8	355,6	396,9	431,8	431,8	473,0
12	315	335	350	375	406,4	419,1	415,9	454,0	495,3	517,5	546,1
14	350	370	390	405	447,7	482,6	479,4	488,9	517,5	574,7	-
16	400	425	445	460	511,2	536,6	533,4	561,9	571,5	638,1	-
18	450	480	500	525	546,1	593,7	590,5	609,6	635,0	701,7	-
20	500	535	555	575	603,2	650,9	644,5	679,5	695,3	752,4	-
24	600	640	665	685	714,4	771,5	765,2	787,4	835,0	898,5	-

- Flanges compliant with the standard not available

Dimensions in mm

1) Specify material when placing order
2) Please arrange other thicknesses when ordering.





GROOVED GASKETS

Metal/soft-material gaskets

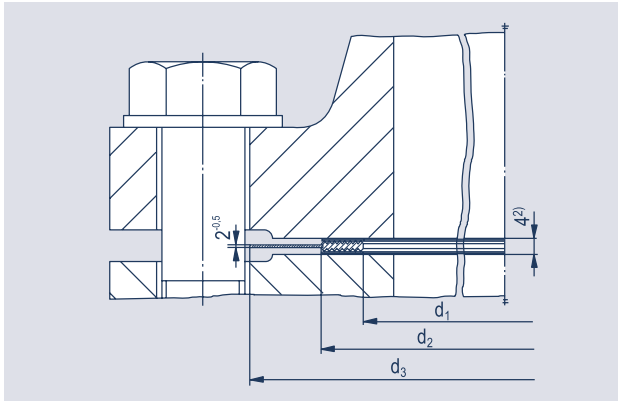

Works standard 147 for flanges

in accordance with ASME B16.47 Series A

Ordering example for a grooved gasket with layers,
Profile B9A, NPS 30, for flanges
in accordance with ASME B16.47, Series A, Class 600,
works standard 147, made of ...1):

**Grooved gasket B9A, NPS 30, Class 600,
works standard 147, 1.4541 / graphite**

For flanges in accordance with ASME B16.47 Series A

NPS	d ₁	d ₂ Class 150-300	d ₂ Class 400-600	d ₂ Class 900-2500	Class		d ₃		
					150	300	400	600	900
26	650	685	705	725	772	832	829	864	880
28	705	745	765	785	829	895	889	911	943
30	755	795	820	840	880	949	943	968	1007
32	805	850	875	895	937	1003	1000	1019	1070
34	855	900	930	950	987	1054	1051	1070	1134
36	905	955	985	1005	1045	1114	1114	1127	1197
38	960	1015	1030	1065	1108	1051	1070	1102	1197
40	1010	1065	1085	1120	1159	1111	1124	1153	1248
42	1060	1120	1135	1175	1216	1162	1175	1216	1299
44	1110	1170	1190	1230	1273	1216	1229	1267	1365
46	1160	1225	1250	1285	1324	1270	1286	1324	1432
48	1210	1275	1300	1340	1381	1321	1343	1388	1483
50	1260	1330	1355	-	1432	1375	1400	1445	-
52	1310	1385	1405	-	1489	1426	1451	1495	-
54	1360	1435	1460	-	1546	1489	1515	1553	-
56	1410	1490	1515	-	1603	1540	1565	1610	-
58	1460	1540	1565	-	1661	1591	1616	1661	-
60	1510	1595	1625	-	1711	1742	1680	1730	-

- Flanges compliant with the standard not available

Dimensions in mm

1) Specify material when placing order
2) Please arrange other thicknesses when ordering.





GROOVED GASKETS

Metal/soft-material gaskets

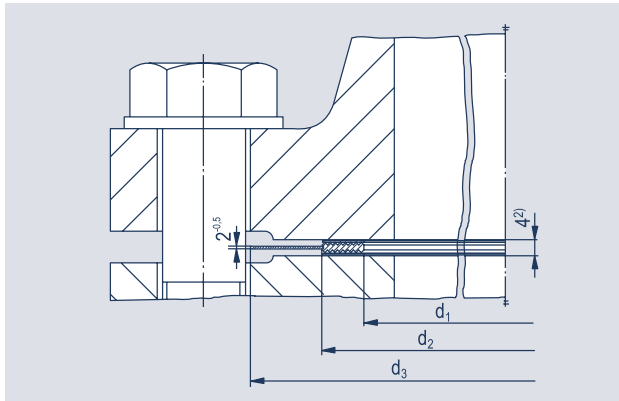

Works standard 101* for DIN flanges

Ordering example for a grooved gasket with layers, Profile B29A, DN 100, PN 40, works standard 101, made of ...¹⁾:

Grooved gasket B29A, DN 100, PN 40, works standard 101, 1.4541 / PTFE

* Grooved gaskets can also be manufactured with a sealing width optimised to the nominal pressure in accordance with works standard 145

For DIN flanges

DN	d ₁	d ₂	d ₃									
			PN 10	PN 16	PN 25	PN 40	PN 63	PN 100	PN 160	PN 250	PN 320	PN 400
10	22	36	46	46	46	46	56	56	56	67	67	67
15	26	42	51	51	51	51	61	61	61	72	72	78
20	31	47	61	61	61	61	-	-	-	-	-	-
25	36	52	71	71	71	71	82	82	82	83	92	104
32	46	66	82	82	82	82	-	-	-	-	-	-
40	53	73	92	92	92	92	103	103	103	109	119	135
50	65	87	107	107	107	107	113	119	119	124	134	150
65	81	103	127	127	127	127	137	143	143	153	170	192
80	95	121	142	142	142	142	148	154	154	170	190	207
100	118	144	162	162	168	168	174	180	180	202	229	256
125	142	176	192	192	194	194	210	217	217	242	274	301
150	170	204	217	217	224	224	247	257	257	284	311	348
175	195	229	247	247	254	265	277	287	284	316	358	402
200	224	258	272	272	284	290	309	324	324	358	398	442
250	275	315	327	328	340	352	364	391	388	442	488	-
300	325	365	377	383	400	417	424	458	458	536	-	-
350	375	420	437	443	457	474	486	512	-	-	-	-
400	426	474	489	495	514	546	543	572	-	-	-	-
450	480	528	539	555	-	571	-	-	-	-	-	-
500	530	578	594	617	624	628	657	704	-	-	-	-
600	630	680	695	734	731	747	764	813	-	-	-	-
700	730	780	810	804	833	852	879	950	-	-	-	-
800	830	880	917	911	942	974	988					
900	930	980	1017	1011	1042	1084	1108					
1000	1040	1090	1124	1128	1154	1194	1220					
1200	1250	1310	1341	1342	1364	1398	1452					
1400	1440	1510	1548	1542	1578	1618	-					
1600	1650	1730	1772	1764	1798	1830	-					
1800	1850	1930	1972	1964	2000	-	-					
2000	2050	2130	2182	2168	2230	-	-					
2200	2250	2340	2384	2378	-	-	-					
2400	2460	2550	2594	-	-	-	-					
2600	2670	2760	2794	-	-	-	-					
2800	2890	2980	3014	-	-	-	-					
3000	3100	3190	3228	-	-	-	-					

- Flanges compliant with the standard not available

Dimensions in mm

1) Specify material when placing order

2) The thickness of the metal part 3.8^{±0.2} mm at a nominal size of 4. Please arrange other thicknesses when ordering.





GROOVED GASKETS

Metal/soft-material gaskets

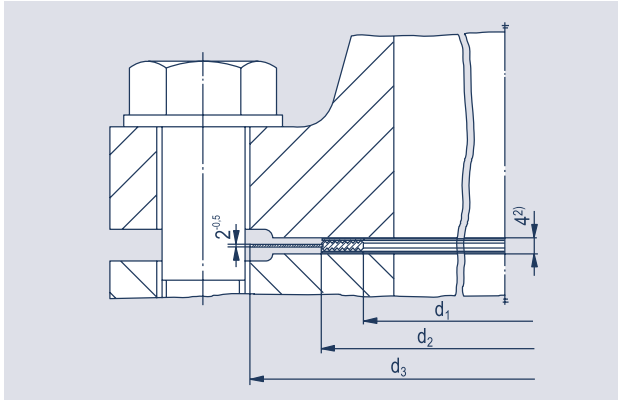

Works standard 100* = EN 12560-6 for flanges in accordance with ANSI B16.5

Ordering example for a grooved gasket with layers, Profile B9A, NPS 5, for ANSI flanges, Class 600, works standard 100, made of ...¹⁾:

Grooved gasket B9A, NPS 5, Class 600, works standard 100, 1.4541/graphite

* Grooved gaskets can also be manufactured with a sealing width optimised to the nominal pressure in accordance with works standard 146

For flanges in accordance with ANSI B16.5

NPS	d ₁	d ₂	Class		d ₃				
			150	300	400	600	900	1500	2500
1/2	23,0	33,3	44,4	50,8	50,8	50,8	60,3	60,3	66,7
3/4	28,6	39,7	53,9	63,5	63,5	63,5	66,7	66,7	73,0
1	36,5	47,6	63,5	69,8	69,8	69,8	76,2	76,2	82,5
1 1/4	44,4	60,3	73,0	79,4	79,4	79,4	85,7	85,7	101,6
1 1/2	52,4	69,8	82,5	92,1	92,1	92,1	95,2	95,2	114,3
2	69,8	88,9	101,8	108,0	108,0	108,0	139,7	139,7	142,8
2 1/2	82,5	101,6	120,6	127,0	127,0	127,0	161,9	161,9	165,1
3	98,4	123,8	133,4	146,1	146,1	146,1	165,1	171,5	193,7
3 1/2	111,1	136,5	158,8	161,9	158,7	158,7	-	-	-
4	123,8	154,0	171,5	177,8	174,6	190,5	203,2	206,4	231,7
5	150,8	182,6	193,7	212,7	209,5	238,1	244,5	250,8	276,2
6	177,8	212,7	219,1	247,7	244,5	263,5	285,8	279,4	314,3
8	228,6	266,7	276,2	304,8	301,6	317,5	355,6	349,3	384,1
10	282,6	320,7	336,5	358,8	355,6	396,9	431,8	431,8	473,0
12	339,7	377,8	406,4	419,1	415,9	454,0	495,3	517,5	546,1
14	371,5	409,6	447,7	482,6	479,4	488,9	517,5	574,7	-
16	422,3	466,7	511,2	536,6	533,4	561,9	571,5	638,1	-
18	479,4	530,2	546,1	593,7	590,5	609,6	635,0	701,7	-
20	530,2	581,0	603,2	650,9	644,5	679,5	695,3	752,4	-
22	581,0	631,8	657,2	701,7	698,5	730,3	-	-	-
24	631,8	682,6	714,4	771,5	765,2	787,4	835,0	898,5	-

- Flanges compliant with the standard not available

Dimensions in mm

¹⁾ Specify material when placing order





GROOVED GASKETS
Metal/soft-material gaskets

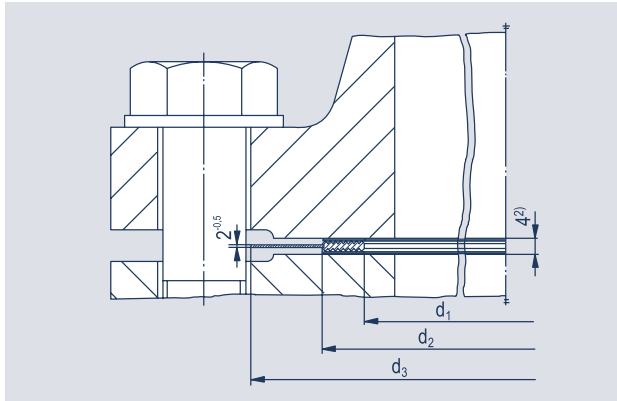

**Works standard 136* for flanges
in accordance with ASME B16.47 Series A**

Ordering example for a grooved gasket with layers, Profile B9A, NPS 30, for flanges in accordance with ASME B16.47, Series A, Class 600, works standard 136, made of ...¹⁾:

**Grooved gasket B9A, NPS 30, Class 600,
works standard 136, 1.4541 / graphite**

* Grooved gaskets can also be manufactured with a sealing width optimised to the nominal pressure in accordance with works standard 147

For flanges in accordance with ASME B16.47 Series A

NPS	d ₁	d ₂	Class				
			150	300	400	600	900
26	690	740	772	832	829	864	880
28	740	790	829	895	889	911	943
30	800	850	880	949	943	968	1007
32	845	905	937	1003	1000	1019	1070
34	895	955	987	1054	1051	1070	1134
36	950	1010	1045	1114	1114	1127	1197
38	960	1020	1108	1051	1070	1102	1197
40	1015	1075	1159	1111	1124	1153	1248
42	1065	1125	1216	1162	1175	1216	1299
44	1125	1185	1273	1216	1229	1267	1365
46	1175	1235	1324	1270	1286	1324	1432
48	1220	1290	1381	1321	1343	1388	1483
50	1270	1350	1432	1375	1400	1445	-
52	1320	1400	1489	1426	1451	1495	-
54	1375	1455	1546	1489	1515	1553	-
56	1430	1510	1603	1540	1565	1610	-
58	1485	1565	1661	1591	1616	1661	-
60	1535	1615	1711	1742	1680	1730	-

- Flanges compliant with the standard not available

Dimensions in mm

1) Specify material when placing order
2) The thickness of the metal part 3.8^{±0.2} mm at a nominal size of 4. Please arrange other thicknesses when ordering.





GROOVED GASKETS

Metal/soft-material gaskets

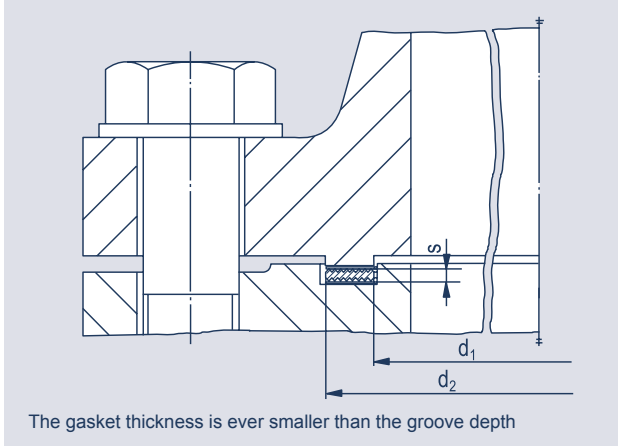

For flanges with tongue and groove

Conforms to DIN 2691 edition 11.71 (PN 10 to PN 160)

Ordering example for a grooved gasket with layers, Profile B7A, DN100, made of ...¹⁾:

Grooved gasket, B7A, DN 100, DIN 2691, 1.4571 / graphite

For DIN flanges

DN	d ₁	d ₂
4-6 ²⁾	20	30
8 ²⁾	22	32
10	24	34
15	29	39
20	36	50
25	43	57
32	51	65
40	61	75
50	73	87
65	95	109
80	106	120
100	129	149
125	155	175
150	183	203
175	213	233
200	239	259
250	292	312
300	343	363
350	395	421
400	447	473
500	549	575
600	649	675
700	751	777
800	856	882
900	961	987
1000	1062 ³⁾	1092 ³⁾

Dimensions in mm

1) Specify material when placing order
 2) Only for flanges in refrigeration engineering
 3) Dimensions in accordance with DIN 2512

In accordance with ANSI B 16.21 (150 to 1500)

Ordering example for a grooved gasket with layers, Profile B7A, NPS 5, wide model, made of ...¹⁾:

Grooved gasket, B7A, NPS 5, ANSI B 16.5 wide, tongue and groove, 1.4541 / graphite

For flanges in accordance with ASME/ANSI B16.5

NPS	d ₁	narrow d ₂	wide d ₂
½	25	35	35
¾	33	43	43
1	38	48	51
1¼	48	57	64
1½	54	64	73
2	73	83	92
2½	86	95	105
3	108	117	127
3½	121	130	140
4	132	145	157
5	160	173	186
6	191	203	216
8	238	254	270
10	286	305	324
12	343	362	381
14	375	394	413
16	425	448	470
18	489	511	533
20	533	559	584
24	641	667	692

Dimensions in mm



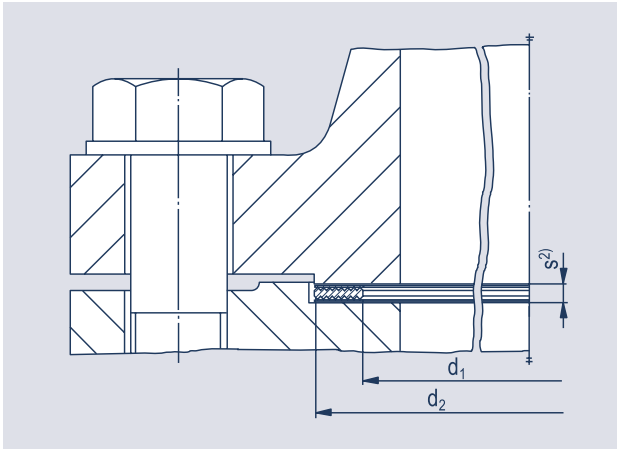

For flanges with male and female

Conforms to DIN 2692 edition 5.66 (PN 10 to PN 100)

Ordering example for a grooved gasket with layers,
Profile B7A, DN 100, made of ...¹⁾:

Grooved gasket, B7A, DN 100, DIN 2692, 1.4541 / graphite

For DIN flanges

DN	d ₁	d ₂
10	18	34
15	22	39
20	28	50
25	35	57
32	43	65
40	49	75
50	61	87
65	77	109
80	90	120
100	115	149
125	141	175
150	169	203
175	195	233
200	220	259
250	274	312
300	325	363
350	368	421
400	420	473
500	520	575
600	620	675
700	720	777
800	820	882
900	920	987
1000	1020	1091

Dimensions in mm

In accordance with ANSI B16.21 (150 to 1500)

Ordering example for a grooved gasket with layers, Profile B7A,
NPS 5, wide model, made of ...¹⁾:

Grooved gasket, B7A, NPS 5, ANSI B 16.21 wide,
male and female, 1.4541/graphite

For flanges in accordance with ASME/ANSI B16.5

NPS	narrow		wide	
	d ₁	d ₂	d ₁	d ₂
1/2		18	21	35
3/4		24	27	43
1		30	34	51
1 1/4		38	42	64
1 1/2		44	48	73
2		57	60	92
2 1/2	to be specified by user	68	73	105
3		84	89	127
3 1/2		97	102	140
4		109	114	157
5		137	141	186
6		162	168	216
8		213	219	270
10		267	273	324
12		318	324	381
14		349	356	413
16		400	406	470
18		451	457	533
20		502	508	584
24		603	610	692

Dimensions in mm

1) Specify material when placing order
2) The gasket thickness is always less than the female face depth