

# ROUND WIRE GASKETS

## Metal gaskets



Round wire gaskets are used in gas and vacuum engineering. Standard materials used include soft-annealed aluminium, copper, silver and nickel.

Lathed rings and rings bended and welded from calibrated wire can be supplied. Round wire gaskets are usually inserted in grooves. Some possible options are shown here.

### Gasket profiles

Profile	Cross-section
A10	

If the gaskets are generally elastically deformed, the sealing surface width arising should first be calculated using the following formula

$$b_D = 100 \cdot \frac{\sigma}{E_D} \cdot r \cdot n \cdot \sin \alpha^2)$$

It should be noted that a small wire and/or sealing diameter will place higher demands on the groove and on the gasket with regard to size, tolerances and surface quality. Lathed rings should be used in this case. With welded models, strong plastic deformation is required.

If the material displays full plasticity, such as aluminium, soft copper, silver or gold, the seal width  $b_D$  is equal to the groove width  $b$ . Full plastic deformation requires much higher bolt loads than the more predominant elastic deformation.

The cross-section surfaces for full plastic deformation should be dimensioned in such a way that the round ring can fill the groove cross-section in its deformed state. Generally a gap of a few tenths of a millimetre should be left.

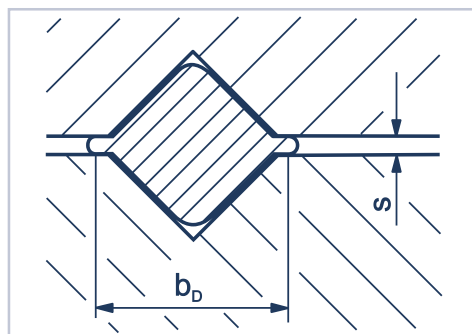

- Specify material when placing order.
- Formula taken from "Optimization of static gaskets" by H.J. Tuckmantel, published by Kempchen.

### Materials

1.0333, 3.0255, 2.0090, 2.4066, fine-grain silver

Further technical data can be found in our section under

### "Materials commonly used"

Ordering example for a round wire gasket, Profile A10 with internal diameter of 110 m and wire diameter of 5 mm made of ...1>:

Round wire gasket, Profile A10, 110 x 5 / 2.0090

### Double-sided contact

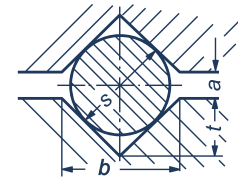

s	b	t	a
2	2,5	1,25	0,16
3	3,8	1,9	0,24
4	5,0	2,5	0,32
5	6,3	3,1	0,40
6	7,5	3,8	0,48
8	10,0	5,0	0,64
10	12,5	6,3	0,80

Dimensions in mm

### Single-sided contact

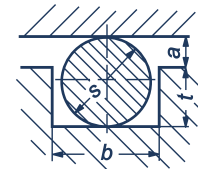

s	b	t	a
2	2,1	1,4	0,6
3	3,3	2,1	0,9
4	4,4	2,8	1,2
5	5,5	3,5	1,5
6	6,6	4,2	1,8
8	8,8	5,6	2,4
10	11,0	7,0	3,0

Dimensions in mm

### Single-sided contact

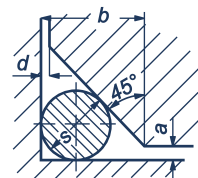

s	b	a
2	2,8	0,6
3	4,2	0,9
4	5,6	1,2
5	7,0	1,5
6	8,4	1,8
8	11,2	2,4
10	14,0	3,0

d is the result from the fit H7/e6

Dimensions in mm

### Gasket limiting values

Profiles	A10					
	Materials	Iron 1.0333	Aluminium 3.0255	Copper 2.0090	Nickel 2.4066	Fine-grain silver
Recommended max. roughness of the flange surfaces	$\mu\text{m}$	from 3,2 to 6,3	3,2 to 6,3	3,2 to 6,3	3,2 to 6,3	3,2 to 6,3
Surface pressure limits for 20 °C	$\text{N/mm}^2$	$\sigma_v$ 265 $\sigma_0$ 600	70 140	135 300	190 510	100 190
E-Modul at 20 °C	$\text{kN/mm}^2$	210	70	128	206	79
Surface pressure limits for 300 °C	$\text{N/mm}^2$	$\sigma_v$ 265 $\sigma_0$ 390	-	135 150	100 480	100 145
E-Modul at 300 °C	$\text{kN/mm}^2$	185	-	114	118	70